

Chris Cutter 3 Twin Cylinder 140 Ton

Big Production. Exceptional Value.



The **New Chris Cutter 3 twin cylinder** package delivers great value for the investment. This machine is ideal for cutting medium hard stones or thin stone into dimension. With the optional 24" high opening, stone can be placed on edge and cleaved or pealed with the bedding grain into flagging.

The Chris Cutter frame is designed to be the most rigid stone splitter frame in the industry and carries the only lifetime guarantee. This rigidity allows all of the cutting force to be immediately transferred to the stone and not absorbed by the frame giving you superior splits and more power to cut the harder stones.

Chris Cutters are designed with ease of operation and durability in mind. The multiple floating teeth with its unique hydraulic locking system gives you a superior cut with any hard or soft stone. With an assortment of options, the Chris Cutter 3 can be customized to meet your individual needs and application. All machines are shipped to you as a turn-key unit, complete with on-site installation and training.

One Year Complete Warranty /
Lifetime Warranty on Frame.

Standard Features & Options:

- Maximum throat height: 12, 16, or 24 inches
- Maximum throat width: 48 inches
- Minimum throat opening: 0.375 inches
- Maximum cutting pressure: 140 tons
- 2.25 or 3 inch diameter hardened steel teeth or carbide inserts
- 2 inches of equalization per tooth on the top and bottom jaws
- Roller inbound and roller outbound tables
- One section of 2' x 10' gravity roller conveyor
- 240/480 volt 3-phase electric powered hydraulic power unit complete with:
 - NEMA 3 rated control enclosure with start, stop and disconnect
 - 100 gal. hydraulic reservoir filled with AW46 hydraulic oil
 - Sight/Temperature gauge
 - Filter assembly
 - 2-stage hydraulic pump



Also available with EPA compliant
Diesel Power Unit

For more information call or visit: 800-350-9313 www.CeeJayTool.com

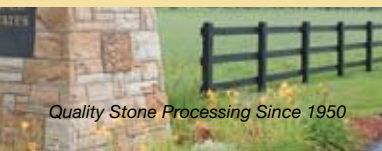

Quality Stone Processing Since 1950

5100 Boyd Lake Ave., Loveland, CO 800-350-9313 www.ceejaytool.com

**CEE-JAY TOOL
COMPANY, INC**



Chris Cutter 3 Dimensions:

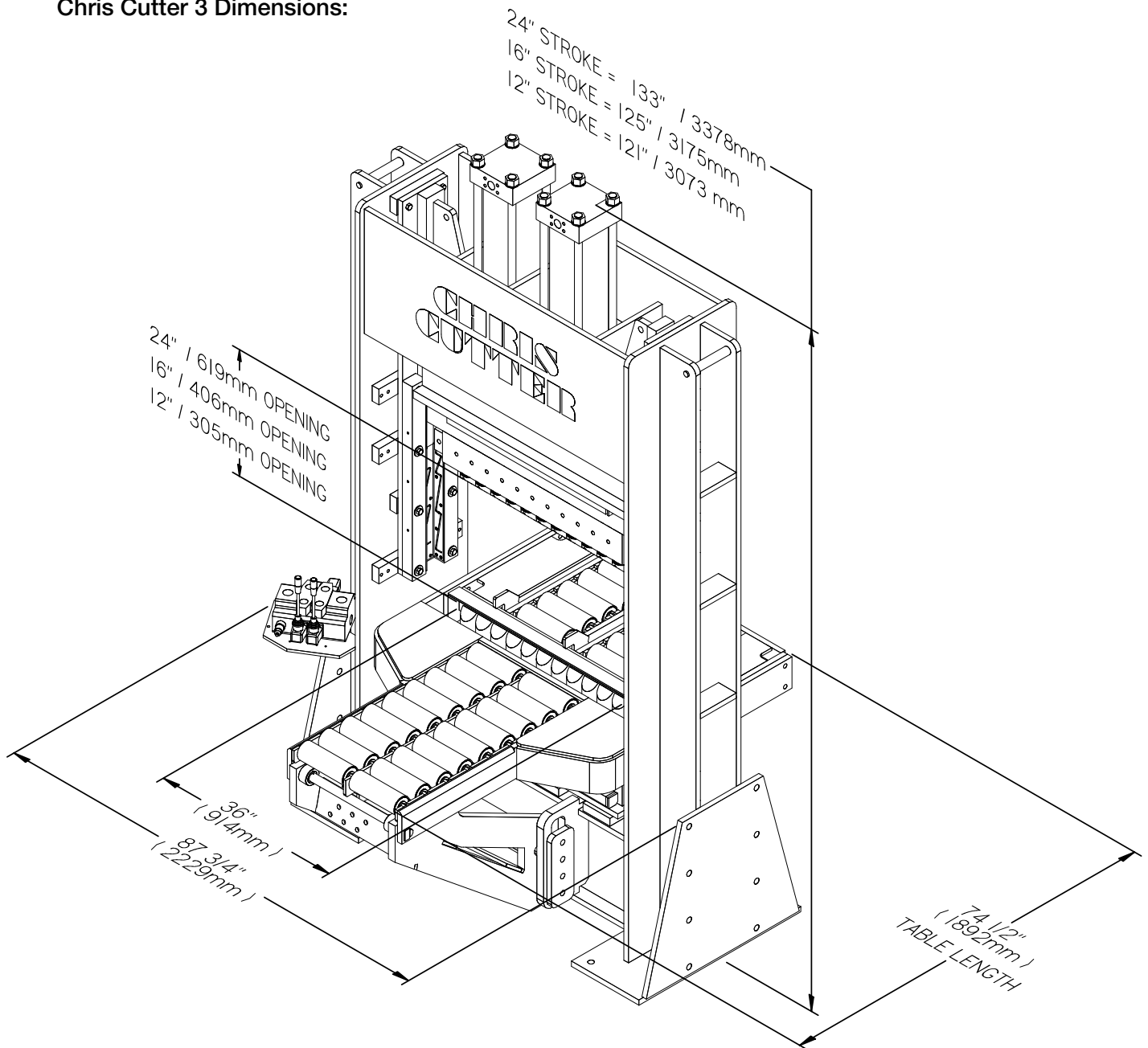

Chris Cutter 4 350 Ton

The Right Machine for the Job.



The **Chris Cutter 4** package is ideal for the quarry that is processing stone less than 4ft wide, but is hard enough to require 350 tons of cutting force. Available in 12-inch, 16-inch and 24-inch throat openings.

All Chris Cutters are designed with ease of operation and durability in mind. The multiple floating teeth with its unique hydraulic locking system gives you a superior cut with any hard or soft stone. With an assortment of options, the Chris Cutter 4 can be customized to meet your individual needs and application. All machines are shipped to you as a turn-key unit, complete with on-site installation and training.

One Year Complete Warranty /
Lifetime Warranty on Frame.

Specifications:

- Maximum throat height: 12, 16, or 24 inches
- Maximum throat width: 48 inches
- Minimum throat opening: 0.375 inches
- Maximum cutting pressure: 150 tons
- 2.25 or 3 inch diameter hardened steel teeth or carbide inserts
- 2 inches of equalization per tooth on the top and bottom jaws
- Roller inbound and roller outbound tables
- One section of 3' x 10' gravity roller conveyor
- 240/480 volt 3-phase electric powered hydraulic power unit complete with:
 - NEMA 3 rated control enclosure with start, stop and disconnect
 - 100 gal. hydraulic reservoir filled with AW46 hydraulic oil
 - Sight/Temperature gauge
 - Filter assembly
 - 2-stage hydraulic pump



The Chris Cutter frame is designed to be the most rigid stone splitter frame in the industry and carries the only lifetime guarantee. This rigidity allows all of the cutting force to be immediately transferred to the stone and not absorbed by the frame giving you superior splits and more power to cut the harder stones.

For more information call or visit:
800-350-9313 www.CeeJayTool.com



Chris Cutter 4 Dimensions:

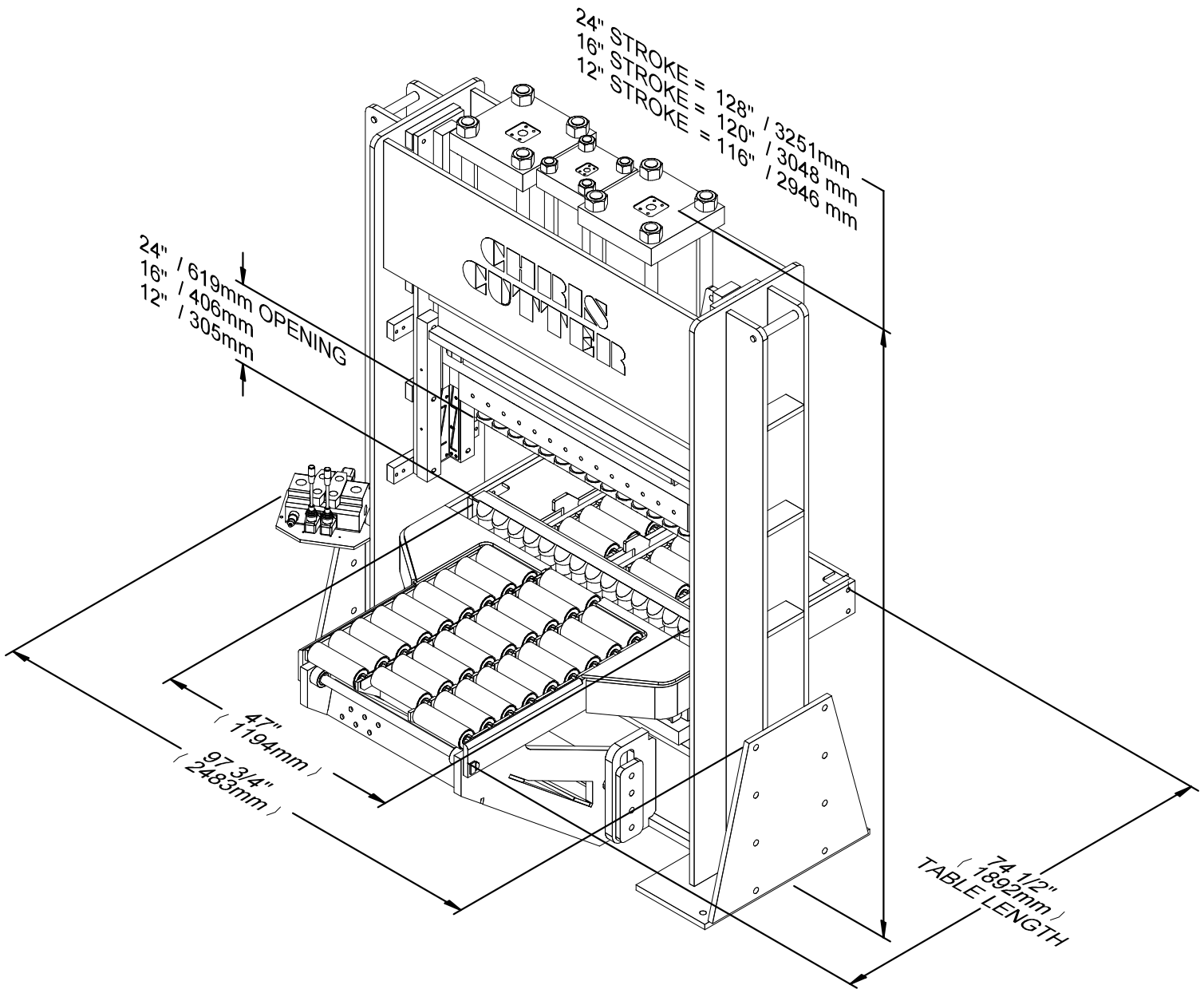

Chris Cutter 5 350 Ton

#1 Selling Package.



The **Chris Cutter 5** is by far our most popular package and the work horse of our fleet. Capable of splitting up to 5 ft. wide pieces of stone, it is well suited to cutting boulders and slabs from 1" to 23" thick into building stones, patio material, coping and step. With our Roller Inbound Outbound Tables large, heavy stone can be moved with ease.

The Chris Cutter 5 package is ideal for the quarry that requires durability and production. A true 350 tons of cutting force leads the stone splitting industry. Available in 12-inch, 16-inch and 24-inch throat openings.

All Chris Cutters are designed with ease of operation and durability in mind. The multiple floating teeth with its unique hydraulic locking system gives you accurate, quality edges with thin slabs or heavy boulders. A variety of options are available and the Chris Cutter 5 can be customized to meet your work flow. All machines are shipped to you as a turn-key unit, complete with on-site installation and training.

One Year Complete Warranty /
Lifetime Warranty on Frame.

Standard Features & Options:

- Maximum throat height: 12, 16, or 24 inches
- Maximum throat width: 72 inches
- Minimum throat opening: 0.375 inches
- Maximum cutting force: 350 tons
- 2.25 or 3 inch diameter hardened steel teeth or carbide inserts
- Veneer gauges
- 2 inches of equalization per tooth on the top and bottom jaws
- Roller inbound and roller outbound tables
- One section of 3 ft. x 10 ft. gravity roller conveyor
- 240/480 volt 3-phase electric powered hydraulic power unit with:
 - NEMA 3 rated control enclosure with start, stop and disconnect
 - 100 gal. hydraulic reservoir filled with AW46 hydraulic oil
 - Sight/Temperature gauge
 - Filter assembly
 - 2-stage hydraulic pump

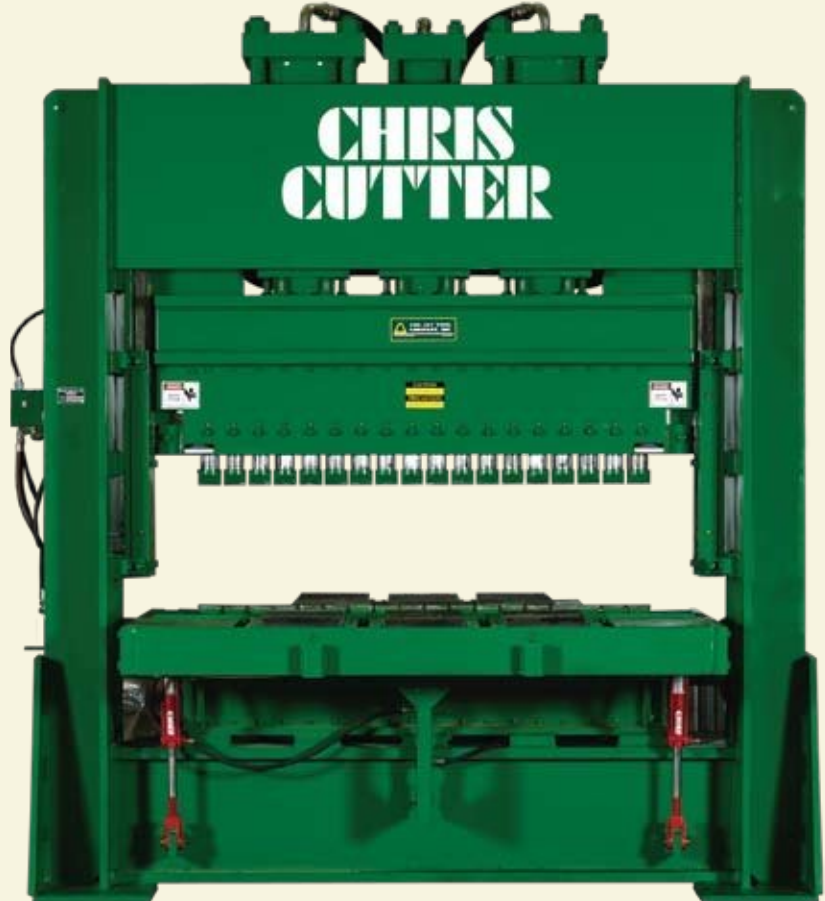

Also available with EPA compliant Diesel Power Unit

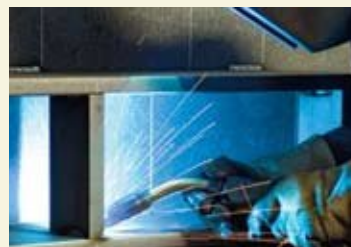

The Chris Cutter frame is designed to be the most rigid stone splitter frame in the industry and carries the only lifetime guarantee. This rigidity allows all of the cutting force to be immediately transferred to the stone and not absorbed by the frame, giving you superior splits and more power to cut the harder stones.

For more information call or visit: **800-350-9313** www.CeeJayTool.com

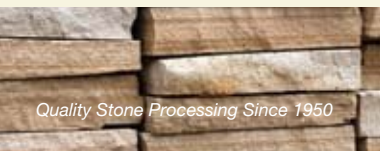

Chris Cutter 5 Dimensions:

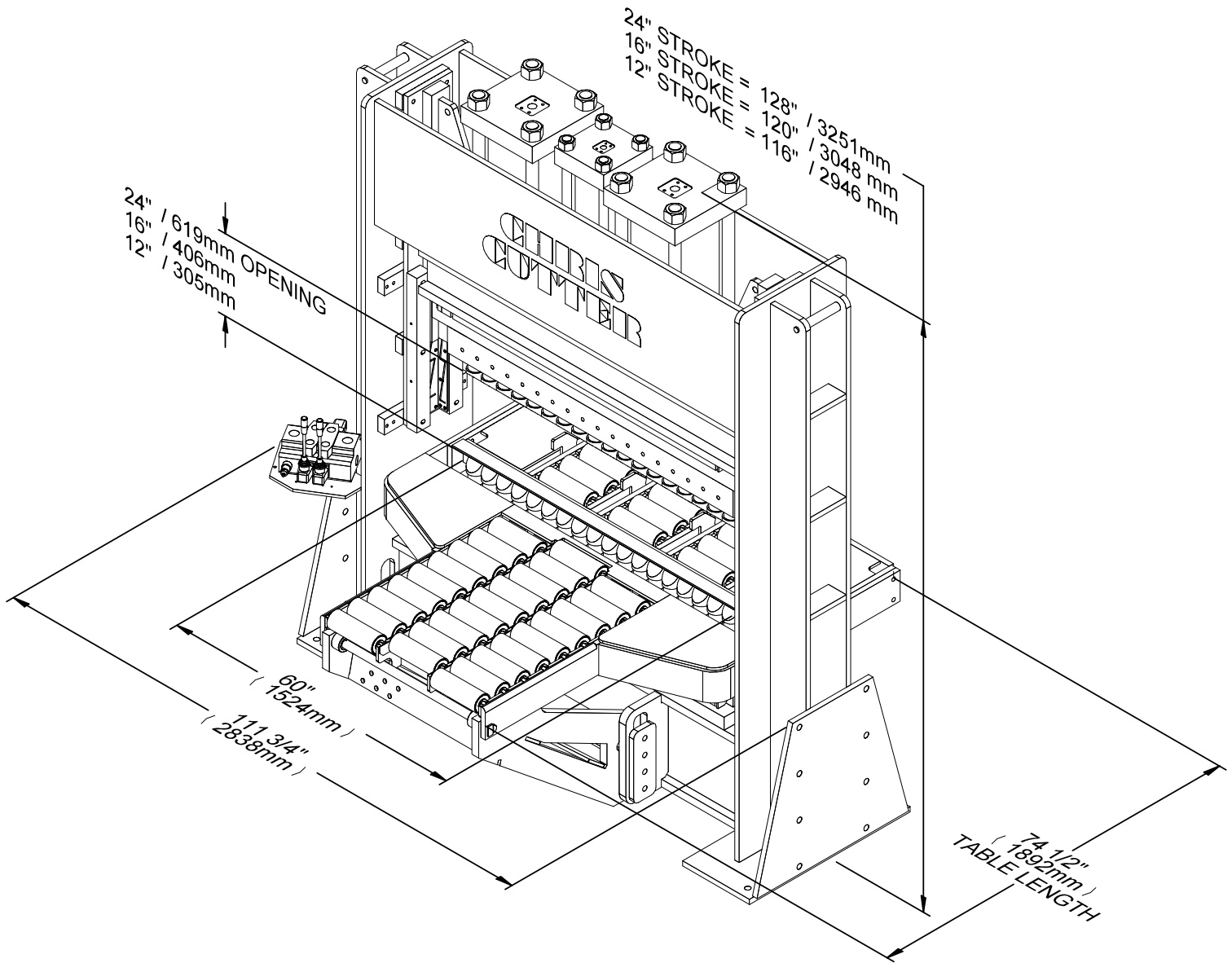

Chris Cutter 7 350 Ton

The Perfect Combination of Strength and Finesse for Big Jobs

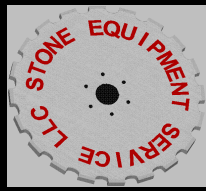

The **Chris Cutter 7** combines strength and finesse to produce dimensional flagstone, cap stone, strip building stone, and stone flooring of hand split quality and craftsmanship.

This cutter may also be modified to meet the unique requirements of the curbing and monument industries. Available in 12-inch, 16-inch and 24-inch throat openings.

All Chris Cutter packages are customized to meet your individual needs. All Chris Cutters are shipped to you as a complete turn-key unit with on-site installation and training included.

One Year Complete Warranty /
Lifetime Warranty on Frame.

Standard Features & Options:

- Maximum throat height: 12, 16, or 24 inches
- Maximum throat width: 96 inches
- Minimum throat opening: 0.375 inches
- Maximum cutting force: 350 tons
- 2.25 or 3 inch diameter hardened steel teeth or carbide inserts
- Veneer gauges
- 2 inches of equalization per tooth on the top and bottom jaws
- Roller inbound and outbound tables
- One section of 3 ft. x 10 ft. gravity roller conveyor
- 240/480 volt 3-phase electric powered hydraulic power unit with:
 - NEMA 3 rated control enclosure with start, stop and disconnect
 - 100 gal. hydraulic reservoir filled with AW46 hydraulic oil
 - Sight/Temperature gauge
 - Filter assembly
 - 2-stage hydraulic pump



Also available with EPA compliant Diesel Power Unit



The Chris Cutter frame is designed to be the most rigid stone splitter frame in the industry and carries the only lifetime guarantee. This rigidity allows all of the cutting force to be immediately transferred to the stone and not absorbed by the frame giving you superior splits and more power to cut the harder stones.

**For more information call or visit:
800-350-9313 www.CeeJayTool.com**





Chris Cutter 7 Dimensions:

